



e28 Mark II Digital to Analogue Converter

8 Channel | PCM 32 bit - 384 kHz

DSD 64 Fs: 2.8224 / 3.072 MHz

DSD 128 Fs: 5.6448 / 6.144 MHz

DSD 256 Fs: 11.2896 / 12.288 MHz

Owner's Manual (Windows)

PLEASE READ BEFORE OPERATION

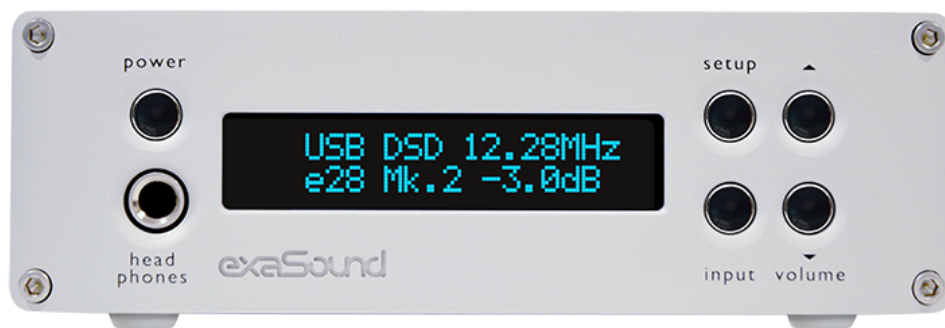

REV. 1.0.1f – 04/2015



Table of Contents

Table of Contents	2
Safety Information	4
Explanation of Graphical Symbols	4
Important Safety Instructions	4
Precautions	4
Welcome	7
e28 Mark II New Features	7
Quick Start	8
Package Contents.....	8
Proper Device Placement.....	8
Front Panel Controls	8
Rear Panel Connectors - RCA	9
Rear Panel Connectors - Mini-XLR	9
Infrared Remote Control.....	10
ASIO Driver Setup.....	10
exaSound Dashboard (Windows).....	11
Features	12
Windows ASIO Driver Advantages	12
Automatic Sampling Rate Switching	12
Automatic PCM / DSD Switching.....	12
Bit-perfect operation independent from the Windows volume control and mixer	12
Asynchronous USB mode eliminates jitter caused by the PC or the USB interface	12
Hardware Volume Control and Volume Bypass.....	13
Volume Control Integration with JRiver/JRemote	13
Connecting and Powering the e28 DAC	14
Connecting the Digital Inputs.....	14
Connecting the Line Outputs	14
Trigger Output.....	14

Direct Connection to Analogue Power Amplifier.....	14
Analogue Interconnect Recommendations	15
Connecting the Power Adapter.....	15
Surge Protectors	15
Isolating the Cable TV Ground	15
Remote Control Setup.....	16
Windows ASIO Drivers Step-by-step Setup Guide.....	17
PC System Requirements.....	17
Windows ASIO Driver Installation.....	17
Configuring Audio Player with ASIO Output	19
Using the e28 DAC	20
Computer Playback Using the Asynchronous USB Input	20
Power On/Off.....	21
Volume Control.....	21
Volume Bypass.....	22
JRiver / JRemote Volume Synchronization Plug-in	22
Settings Menu	23
Step-By-Step Player Configuration Instructions	23
Playing Music from SPDIF Sources.....	23
Specifications.....	24
Limited One Year Warranty.....	26

Safety Information

Explanation of Graphical Symbols

	The lightning flash with arrowhead symbol, within an equilateral triangle, is intended to alert the user to the presence of uninsulated “dangerous voltage” within the product’s enclosure that may be of sufficient magnitude to constitute a risk of electric shock to persons.
	The exclamation point within an equilateral triangle is intended to alert the user to the presence of important operating and maintenance (servicing) instructions in the literature accompanying the Device.



Important Safety Instructions



1. Read these instructions.
2. Keep these instructions.
3. Heed all warnings.
4. Follow all instructions.
5. Do not use this apparatus near water.
6. Clean only with dry cloth.
7. Do not block any ventilation openings. Install in accordance with the manufacturer’s instructions.
8. Do not install near any heat sources such as radiators, heat registers, stoves, or other apparatus (including amplifiers) that produce heat.
9. Do not defeat the safety purpose of the polarized or grounding-type plug. A polarized plug has two blades with one wider than the other. A grounding type plug has two blades and a third grounding prong. The wide blade or the third prong is provided for your safety. If the provided plug does not fit into your outlet, consult an electrician for replacement of the obsolete outlet.
10. Protect the power cord from being walked on or pinched, particularly at plug, receptacle, and the point where it exits from the apparatus.
11. Only use attachments/accessories specified by the manufacturer.
12. Refer all servicing to qualified service personnel. Servicing is required when the device has been damaged in any way, such as power-supply cord or plug is damaged, liquid has been spilled or objects have fallen into the device, the device has been exposed to rain or moisture, does not operate normally, or has been dropped.

Precautions

- Before connecting the AC power adapter cord to the device, make sure the voltage designation of the power adapter corresponds to the local electrical supply. If you are unsure of your power supply, contact your local power company. The acceptable power input range is AC ~ 100V-240V, 50/60Hz
- The device is still receiving power from the AC power source as long as it is connected to the wall outlet, even if the device itself has been turned off.
- Unplug the power adapter if you are not going to use the device for an extended period of time. Hold the power adapter when unplugging. Do not pull on the cord.

- The power adapter is used as the mechanism for cutting off power, therefore make sure it is easy to unplug.
- To ensure proper ventilation around this product, do not place this product on a sofa, bed or rug.
- High temperature will lead to abnormal operation of this device. Do not expose this device or batteries to direct sunlight or near heating objects.
- When moving the device from a cold location to a warm one, or vice versa, moisture may condense on components inside the device. Should this occur, the device may not operate properly. In such a case please turn the device off for 1-2 hours to facilitate moisture evaporation.

	<p>WARNING: TO REDUCE THE RISK OF FIRE OR ELECTRIC SHOCK, DO NOT EXPOSE THIS DEVICE TO RAIN OR MOISTURE. DANGEROUS HIGH VOLTAGES MAY BE PRESENT INSIDE THE ENCLOSURE. DO NOT OPEN THE CABINET. REFER SERVICING TO QUALIFIED PERSONNEL ONLY. THE DEVICE SHALL NOT BE EXPOSED TO DRIPPING OR SPLASHING AND THAT NO OBJECTS FILLED WITH LIQUIDS, SUCH AS VASES SHALL BE PLACED ON THE APPARATUS.</p>
	<p>WARNING: CHANGES OR MODIFICATIONS NOT AUTHORIZED BY THE MANUFACTURER CAN INVALIDATE THE COMPLIANCE TO REGULATIONS AND CAUSE THE UNIT TO BE NO MORE SUITABLE TO USE. THE MANUFACTURER REFUSES EVERY RESPONSIBILITY REGARDING DAMAGES TO PEOPLE OR THINGS DUE TO THE USE OF A UNIT WHICH HAS BEEN SUBJECT TO UNAUTHORIZED MODIFICATIONS OR TO MISUSE OR TO MALFUNCTION OF A UNIT WHICH HAS BEEN SUBJECT TO UNAUTHORIZED MODIFICATIONS.</p>
<p>FCC Statement</p>	<p>This equipment has been tested and found to comply with the limits for a Class B digital device, pursuant to Part 15 of the FCC Rules. These limits are designed to provide reasonable protection against harmful interference in a residential installation. This equipment generates, uses, and can radiate radio frequency energy and, if not installed and used in accordance with the instructions, may cause harmful interference to radio communications. However, there is no guarantee that interference will not occur in a particular installation. If this equipment does cause harmful interference to radio or television reception, which can be determined by turning the equipment off and on, the user is encouraged to try to correct the interference by one or more of the following measures:</p> <ul style="list-style-type: none"> • Reorient or relocate the receiving antenna. • Increase the separation between the equipment and receiver. • Consult the dealer or an experienced radio/TV technician for help. <p>Any unauthorized changes or modifications to this equipment would void the user's authority to operate this device. This device complies with Part 15 of the FCC Rules. Operation is subject to the following two conditions: (1) This device may not cause harmful interference, and (2) this device must accept any interference received, including interference that may cause undesired operation.</p>
	<p>This unit is compliant with the following CE regulations when an USB cable less than 3m is used: CEI EN 55022:2009 Class B (Radiated Emissions), CEI EN 55024:1999, CEI EN 55024:A2/2003, CEI EN 55024:IS1/2008 (Radio Frequency Electromagnetic Fields, 50Hz Magnetic Field Immunity Test and Electrostatic Discharges – ESD).</p>

	<p>This product, when no longer usable, when disposed off can't be treated as generic garbage, but must be disposed of at a collection point for recycling of electrical and electronic equipment, in compliance with the WEEE regulation (Waste of Electrical and Electronic Equipment).</p> <p>By making sure that this unit is correctly recycled, you will help preventing potential damages to environment and human health, which could be caused by the incorrect treatment of this product as generic garbage. Materials recycling helps conserve natural resources.</p>
	<p>We use our best efforts to ensure that information in this document is complete, accurate and current, but otherwise we make no representation concerning the same. We reserve the right to change or modify the information any time, without prior advice. It's up to the customer to ensure that the manual being consulted is the latest version.</p>
	<p>ASIO is a registered trademark of Steinberg Media Technologies GmbH</p>
<p>Trade marks</p>	<ul style="list-style-type: none"> ▪ Direct Stream Digital (DSD) is a trademark of Sony Corporation. ▪ Designed for Windows Media, Microsoft, HDCD, and the HDCD logo are trademarks or registered trademarks of Microsoft Corporation in the United States and/or other countries. ▪ Apple, Mac and OS X are trademarks of Apple, Inc. ▪ All other trademarks are the properties of their respective owners.

Welcome

Thank you for purchasing the exaSound e28 Mark II DAC!

The e28 DAC brings the highest quality of stereo and multichannel music reproduction to computer audiophiles. It delivers up to 8 channels with unprecedented bit-perfect low-jitter precision. e28 supports PCM at sampling rates up to 32bit/384kHz, and DSD 256 Fs up to 12.288 MHz.

We hope that the e28 DAC will help you to enjoy world-class music experience for years to come. Please take a few minutes to read right through this manual. Investing a little time now is the best way to ensure that you make the most of your investment.

Your satisfaction is our highest priority.

Happy listening,

exaSound Audio Design

www.exaSound.com

CustomerService@exaSound.com

e28 Mark II New Features

New e28 Mark II features include:

- Redesigned, more substantial and deeply sculpted front panel
- Auto-power up after sleep
- User adjustable power down after inactivity
- Maximum volume limiter allows the e28 to directly drive a power amplifier while protecting your loudspeakers from damaging overloads
- MP3Safe™ software protection against clipping caused by faulty or erroneous signal processing and data manipulation. MP3Safe analyzes incoming musical information, and safeguards against poorly formed data words caused by errors in lossy encoding and digital signal processing. MP3Safe takes the crunch out of your lower resolution music
- The ability to extinguish the display light via the e28's included IR remote for no visual distractions while listening
- A 12V trigger output has been added for amplifier sequencing and automation

Quick Start

Package Contents

The following items should be in the box:

- e28 DAC
- Power supply
- A-B USB cable
- IR Remote Control

Proper Device Placement

Place the device on a stable solid base, far from heat sources. Do not expose the device to direct sunlight. Allow at least 2.5 cm (1") around the device for ventilation. Do not place the device on fabrics, inside enclosed space, or in contact with curtains. Do not place the device on top of power amplifiers or any other equipment that emits heat. Do not expose the unit to smoke, humidity, moisture and water.

Keep the length of analogue interconnects and speaker cables short for optimal sonic performance. Remember that cables act as filters. Shorter cables have less impact on sonic performance. The shorter the cables, the more transparent they become.

Front Panel Controls

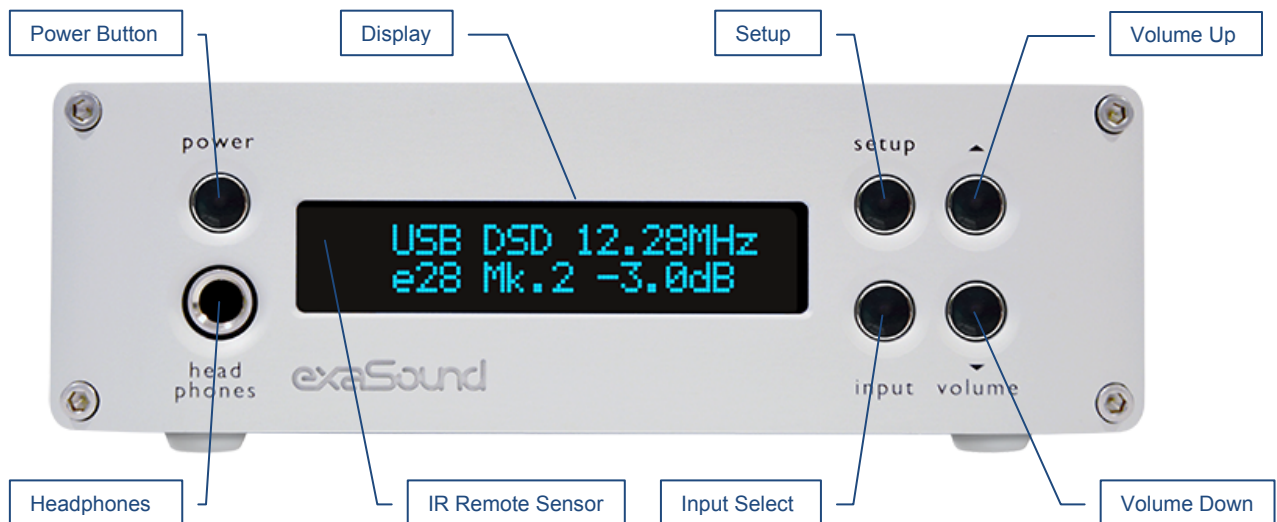

Headphones accepts a standard 1/4-inch stereo single-ended phone plug. Use a suitable adapter for headphones equipped with a different plug.

Rear Panel Connectors - RCA

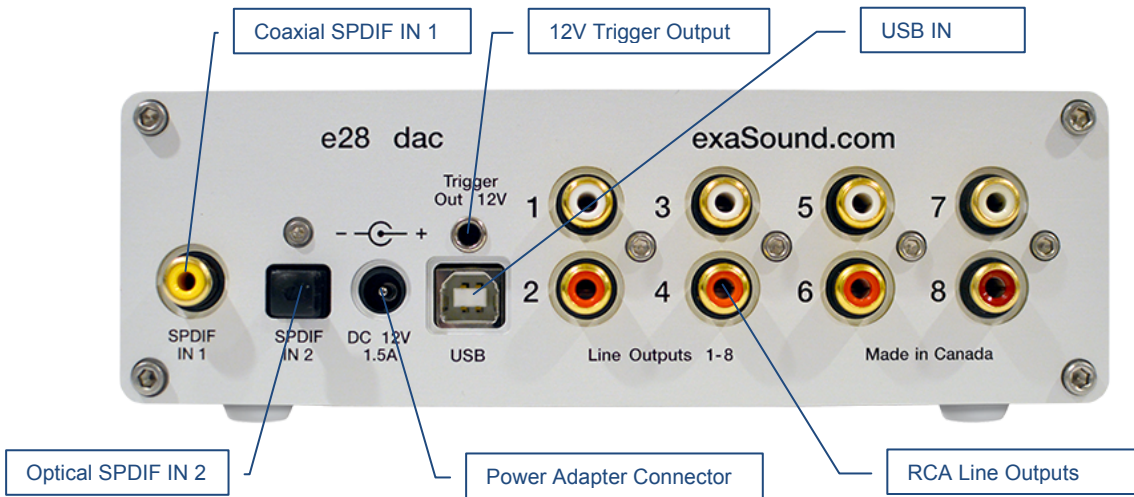

Rear Panel Connectors - Mini-XLR

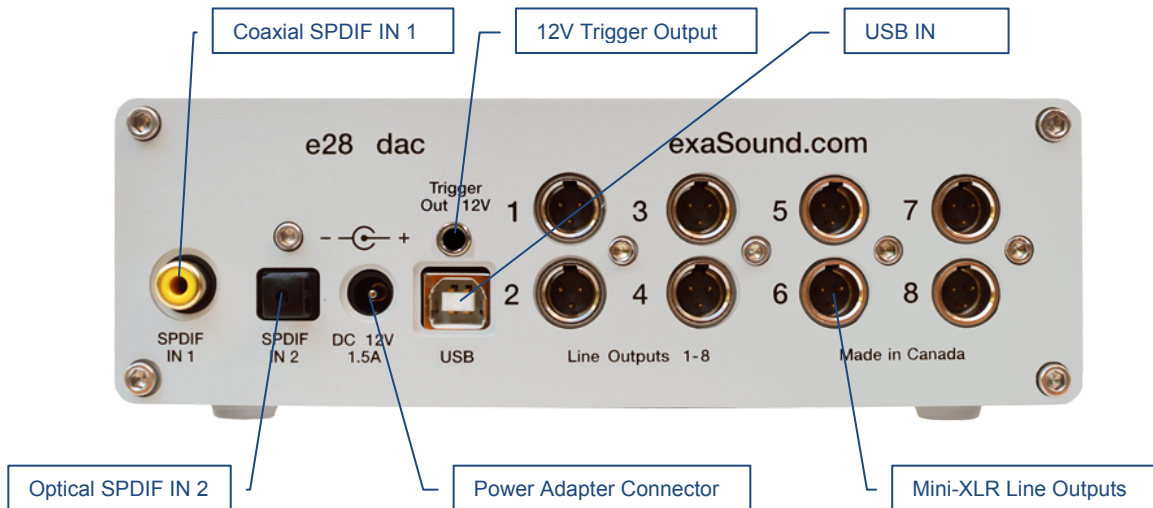

SPDIF IN1 - Coaxial SPDIF Input
SPDIF IN2 - Optical TOSLINK SPDIF Input
DC 12V / 1.5A - Power Adapter Connector
 5.5mm / 2.5mm Outside / Inside Diameter

USB - Classic USB connector
Line Outputs 1-8 - Analogue outputs
 Channel 1 to Channel 8
12V Trigger Output - use to activate trigger-enabled equipment

Infrared Remote Control

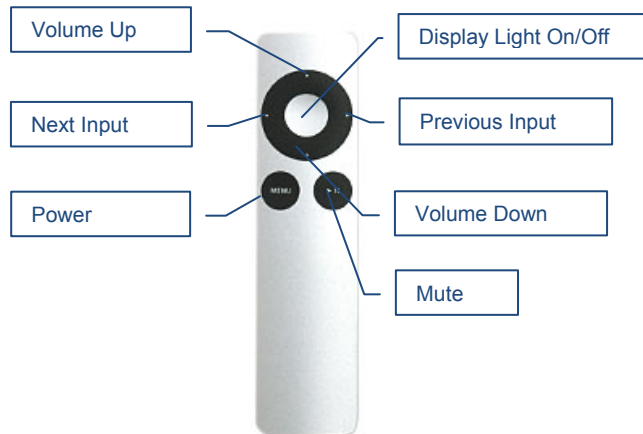

Your unit is pre-programmed to work with the supplied remote control.

The e28 DAC can be re-programmed to work with most infrared remote controls using Sony and NEC IR protocols, for example the Sony RM-EZ4 Universal Remote, or the Apple Remote Control.

See the **Remote Control Setup** section for instructions on how to change button assignments and how to pair a different remote control with your e28 DAC.

ASIO Driver Setup

1. Login to <http://support.exasound.com>. Download and unzip the latest **exaSound Windows ASIO Driver**.
2. Run *exaSoundN1 5-1-3 Setup.exe* and follow the prompts. ASIO drivers step-by-step setup instructions are available on page 17 of this guide.
3. Reboot your computer.
4. Setup your ASIO compatible player (J. River Media Center, HQPlayer, Foobar 2000 etc.) to use the exaSound ASIO driver. Check the **Guides** section of the exaSound blog for step-by-step player configuration instructions: <http://exasound.com/Blog.aspx>.
5. Click on the *exaSound Dashboard* Icon next to the clock on the Windows System Tray and set the master volume.

exaSound Dashboard (Windows)

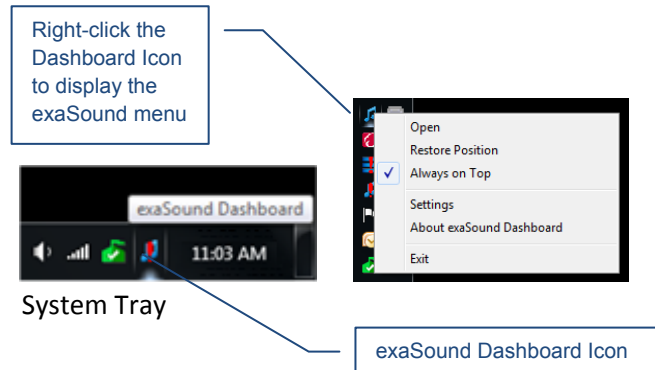
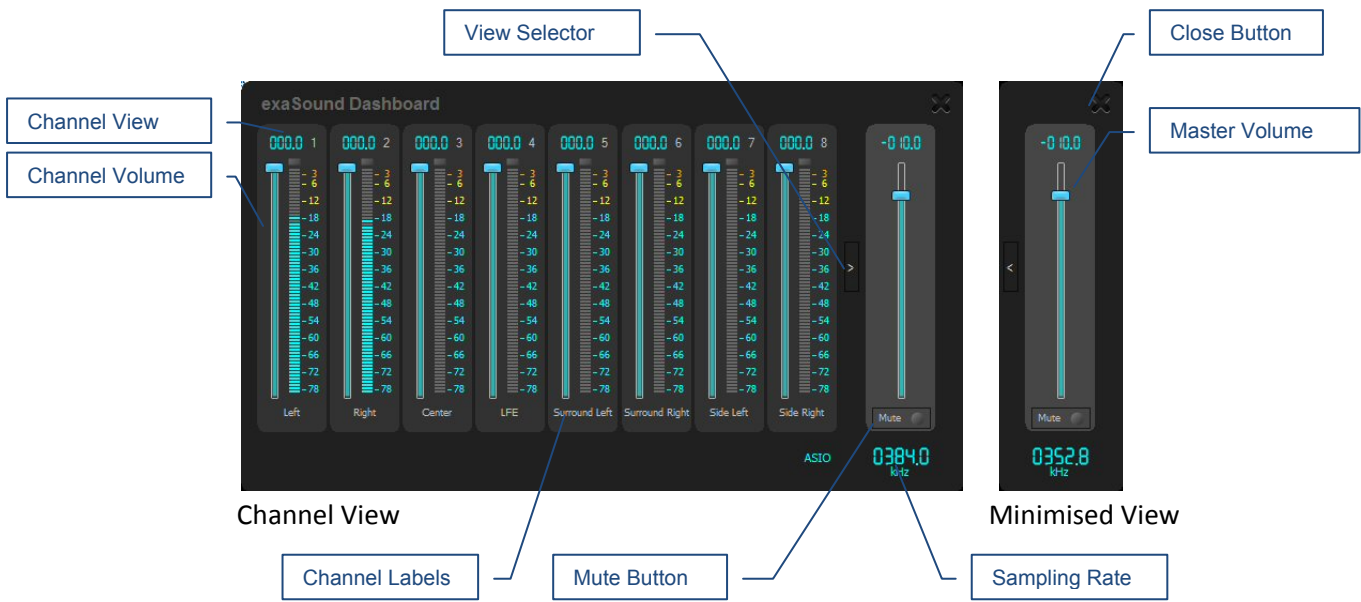

Features

The e28 DAC is based on the ES9018 *Sabre*³² reference DAC chip. It delivers 32-bit precision capable of resolving the smallest signal details. ES9018 features patented 32-bit Hyperstream™ architecture and Time Domain Jitter Eliminator. It delivers the industry's highest performance levels that will satisfy the most demanding audio enthusiasts.

Windows ASIO Driver Advantages

Using ASIO brings unique advantages that are hard to achieve and reliably verify with other Windows driver technologies.

Automatic Sampling Rate Switching

PCM data is always streamed without re-sampling. Native Windows drivers often require manual sampling rate selection and may apply implicit re-sampling when the source rate differs from the rate set in the Windows Control Panel.

Automatic PCM / DSD Switching

Audio data is always streamed in its native format. e28 switches automatically between PCM and DSD modes. DSD streams are processed in their native format without conversion to PCM.

Bit-perfect operation independent from the Windows volume control and mixer

The Windows volume control and mixer are optimized to provide wide compatibility and easiness of use. These features come at the expense of sound quality. The resulting output is not bit-perfect or bit-transparent. Third party proprietary Windows drivers are hard to be verified as bit-perfect because factors beyond the control of the user can change the Windows sound processing chain.

Our proprietary ASIO implementation is completely independent from the Windows sound system and always operates in Exclusive Mode. Only one player can take control of the ASIO driver. When playback starts the player sets the driver sampling rate to be the same as the native rate of the current media file. The sound data stream is delivered to the e28 FIFO memory buffer without any processing or manipulation.

Asynchronous USB mode eliminates jitter caused by the PC or the USB interface

Asynchronous USB is a two-way communication method between a computer and an external USB device. In this method, the USB device is running as a master, and the computer is acting as a slave that delivers data only when requested by the master.

In the case of the e28 DAC, sound data is requested by the FPGA core and stored in the device FIFO memory buffer. The FPGA core makes sure that the buffer never gets empty during playback. Data from the buffer is streamed to the DAC chip. The precision of the timing of the output stream is determined only by the DAC oscillators and it is not degraded in any way by the PC clocks or by delays caused by the USB interface.

Hardware Volume Control and Volume Bypass

The e28 DAC volume is controlled by the ES9018 DAC chip. It is completely independent from the Windows software volume control. Audio data is always bitstreamed over the USB interface at full scale 0db/32bit resolution. Volume processing is performed by the DAC chip right at the border between the digital and the analogue domains. This architecture offers signal to noise ratio comparable to the best analogue volume controls and virtually no loss of digital resolution. Setting the volume to 0dB turns all volume processing off and sets the device in volume bypass mode.

Volume Control Integration with JRiver/JRemote

The exaSound Volume Synchronization Plug-in allows JRiver 20 for Windows and JRemote to access the hardware volume control built in all exaSound DACs.

Connecting and Powering the e28 DAC



Before connecting, turn off the power to all the components in your system.

Connecting the Digital Inputs

All digital inputs are galvanically isolated to eliminate ground loop noise. The e28 DAC accepts three digital inputs

- **USB** - This is the recommended and most capable input. It supports 2 to 8 channels PCM and DSD. PCM is supported with 32 bit resolution at standard sampling frequencies from 44.1 kHz to 384 kHz. DSD sampling rates range from 2.8224 MHz to 12.288 MHz. Connect the e28 DAC to your computer using a standard A-B USB cable.
- **SPDIF IN1** - SPDIF Input, 75-ohm RCA. Supports 2 channels PCM up to 24 bit resolution at standard sampling frequencies from 44.1 kHz to 192 kHz.
- **SPDIF IN2** - SPDIF Input, TOSLINK, Optical. Supports 2 channels PCM up to 24 bit resolution at standard sampling frequencies from 44.1 kHz to 96 kHz.

Connecting the Line Outputs

The e28 DAC offers one of two types of analogue line outputs - unbalanced (RCA) or balanced (Mini-XLR).

- Make sure that your analogue power amplifier is turned off.
- **RCA Line Outputs 1 to 8** - Connect the line outputs of the e28 DAC to the amplifier RCA line inputs.
or
- **XLR Line Outputs 1 to 8** - Connect the Mini- XLR line outputs of the e28 DAC to the amplifier XLR line inputs.

Trigger Output

When the e28 DAC is on, a 12 VDC signal is sent from the Trigger Output to control other devices. When the e28 returns to Standby, the trigger signal is discontinued.

Direct Connection to Analogue Power Amplifier

If your music sources are digital, you don't need a preamplifier. The built-in volume control allows analogue power amplifiers to be connected directly to the e28 DAC. Amplification always brings some level of noise and distortion. Eliminating unnecessary amplification helps to achieve higher level of transparency.



Avoid connecting the e28 DAC to receivers and any other sound processing equipment that performs analogue to digital (ADC) conversion. Digitizing the analogue output signals back to the digital domain for processing will undo the benefits that e28 brings to you. Remember that your sound system is as good as the weakest link in the sound processing chain.

Analogue Interconnect Recommendations

Over-engineered interconnects made from exotic materials are unnecessary. When selecting cables, the following characteristics are important:

- Reliable electrical contact
- Low resistance
- Robust mechanical design

Remember that cables act as filters. The shorter the cable, the more transparent your system will be.

Connecting the Power Adapter

To minimize ground noise and hum, it is recommended to connect the power cords of all components to a single point - usually a single surge protector with multiple outlets. Connecting all components to a single point, as close as it is practically possible minimizes the differences in ground potentials between the components.



Using an Upgraded Power Supply

The e28 DAC comes with a 12V/1670mA power adapter. This power adapter has been tested to comply with the DAC's power supply and quality requirements and allows for very high performance. A better unit may allow you to squeeze the last bit of performance from the e28 DAC. If you decide to use another power supply, the specifications marked on the back of the e28 DAC must be observed.

Surge Protectors

We strongly recommend the use of surge protectors for all of your audio and video components.

Isolating the Cable TV Ground

If you have a cable TV connected to your audio system, ensure that the TV cable ground is galvanically isolated from the audio system ground. The TV cable ground, usually connected to the earth outside your home, can have a significantly different potential than the audio ground. This condition can cause audible hum. If you suspect this is the case, use a cable TV ground isolator just before the cable set-top box or at the RF TV input.



When turning on and off your music system, the power amplifier should be the last component to be turned on and the first component to be turned off. This prevents power on/off transients from being transmitted to the loudspeakers.

Remote Control Setup

The e28 DAC is pre-programmed to work with the supplied remote control. If you like, you can reprogram the e28 DAC to work with a different IR remote control. The exaSound e28 DAC can be trained to recognise commands from most infrared remote controls using Sony and NEC IR protocols.

Use the following procedure to change remote control button assignments or to pair the e28 DAC with a different remote control:

1. Power on the e28 DAC. Make sure that the unit is not in playback mode.
2. Press the **Setup** button.
3. Press the **Volume Up** button to confirm the remote control programming mode, or press the **Volume Down** button to cancel the operation.
4. Point the remote control to the e28 DAC display. Press and hold down the remote control buttons for about one second during each step below to assign functions to them.
5. Press the remote control button for increasing the volume.
6. Press the remote control button for decreasing the volume.
7. Press the remote control button for selecting the next input.
8. Press the remote control button for previous input.
9. Press the remote control button for turning the unit on and off.
10. Press the remote control button for mute.
11. Press the remote control button for turning the display light on and off.
12. Wait until the remote control configuration is saved. Your e28 DAC is now paired for use with the new IR remote control.

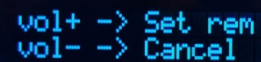

vol+ -> Set rem
vol- -> Cancel

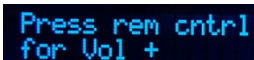

Press rem cntrl
for Vol +



Press rem cntrl
for Vol -

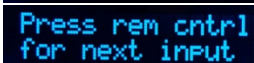

Press rem cntrl
for next input

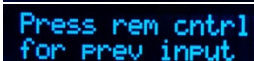

Press rem cntrl
for prev input



Press rem cntrl
for Power



Press rem cntrl
for mute

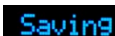

Saving

Windows ASIO Drivers Step-by-step Setup Guide

PC System Requirements

- Operating systems:
 - Windows 8 x86 or Windows 8 x64
 - Windows Server 2012 R2
 - Windows 7, 32 or 64 bit
 - Windows XP / 32 bit with the latest service packs installed
- Recommended CPU for operating at 352.8 and 384 kHz - 2.4GHz dual-core Intel i7 or better
- USB 2.0 / USB 3.0 interface
- 2 GB of RAM
- 10 GB disk space, mainly for music files

Windows ASIO Driver Installation

The first step required in the Windows setup process is to install the exaSound ASIO driver:

1. Don't connect the e28 DAC to the PC until the driver is installed. Don't worry if you've connected the device already. Just disconnect it.
2. Download the latest driver.
You should have received an email from us with username and password. Please login to our support website at <http://support.exasound.com/Downloads.aspx> and download the latest version of the exaSound Windows ASIO Driver. Don't use setup packages downloaded from other websites.
3. Unzip the installation package and double-click on Install.exe to start the installation. Follow the instructions. In most cases you just need to accept the defaults on the following screens.

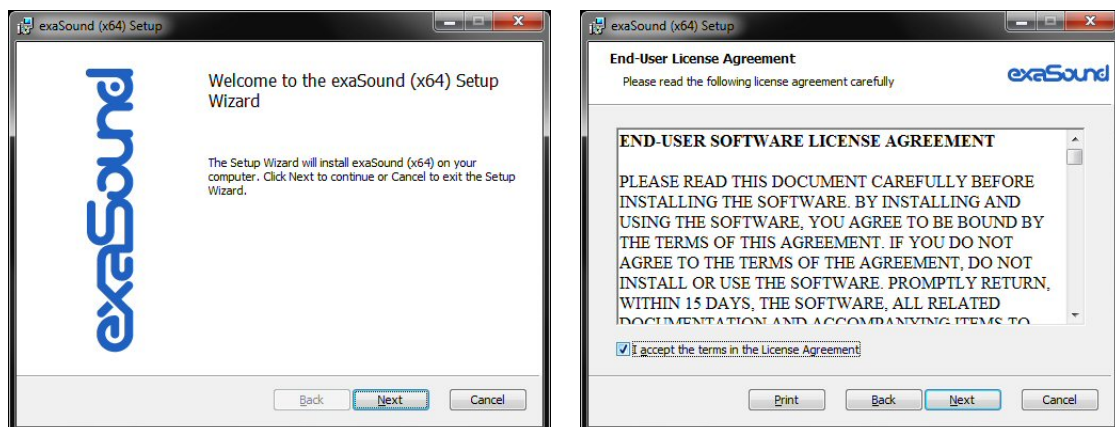

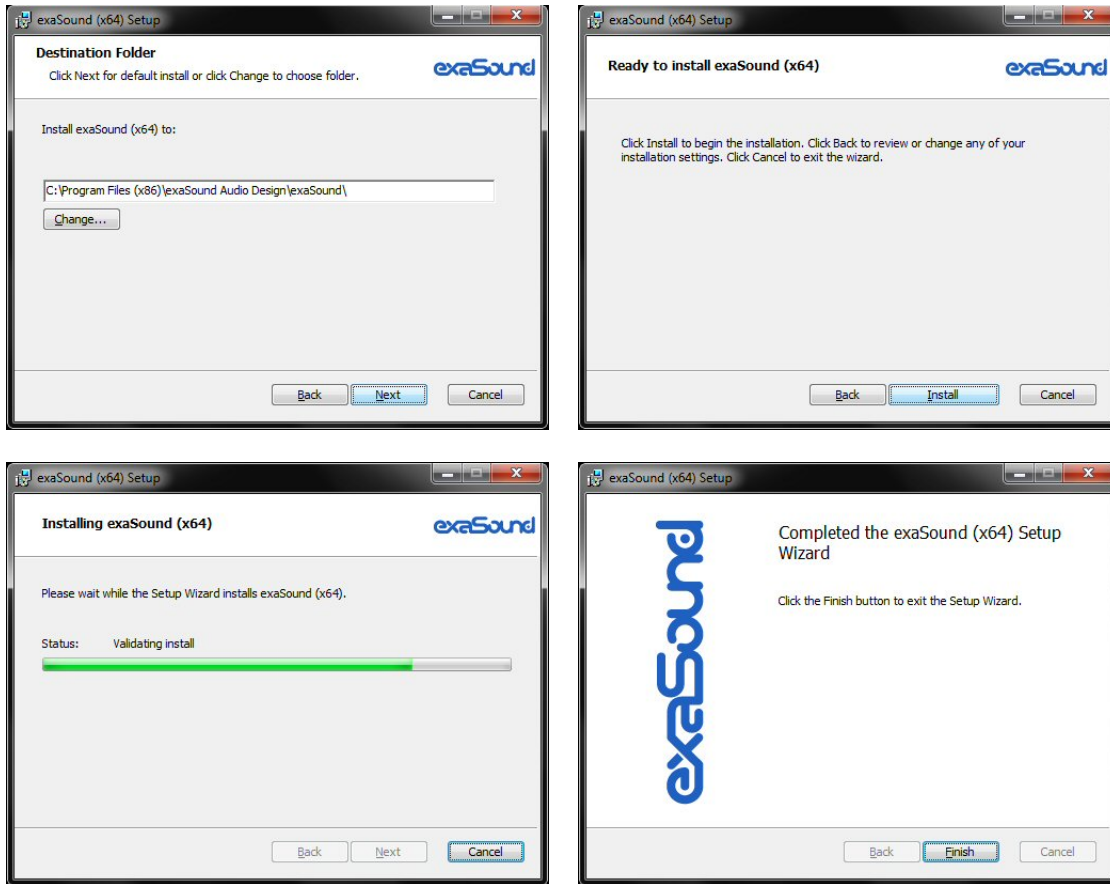

4. Connect the e28 DAC. You should see a pop-up message on the computer screen indicating that e28 DAC is successfully installed. Note that this message has a different appearance on Windows XP and Windows 7. Windows 8 may not display the message.

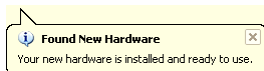



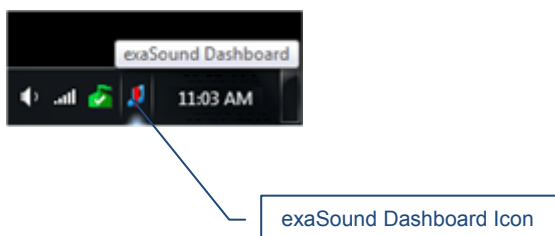

5. Upon completion of the Windows ASIO driver installation you will see the exaSound e28 Dashboard Icon in the System Tray area next to the clock.

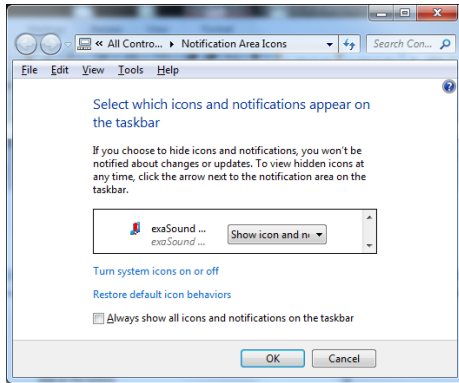

6. If you don't see it, right-click on the clock and select **Customize Notification Icons** from the menu.



7. Scroll down to the exaSound e28 Dashboard icon and from the dropdown select **Show icon and notifications**. Click **OK**.
8. You should be able to see the exaSound e28 Dashboard icons at all times. The Icon changes to indicate playback, and displays an exclamation mark when the USB cable is disconnected:

-  exaSound Dashboard
-  Stop Icon
-  Play Icon
-  USB Cable Disconnected Icon

9. Close all programs and reboot Windows. Some ASIO players may not recognise the driver if you omit this step. If you don't restart Windows you may get an error message: "Hardware not present".

Configuring Audio Player with ASIO Output

You can use most ASIO-enabled software with the e28 DAC. In our experience JRiver Media Center and Foobar2000 provided the best performance and sound quality.

Note: Configuration instructions Foobar2000 and JRiver are available on the exaSound Blog:

<http://www.exasound.com/Blog/tabid/74/articleType/CategoryView/categoryId/10/Guides.aspx>.

Using the e28 DAC

Computer Playback Using the Asynchronous USB Input



Before turning your amplifiers ON, always check the e28 DAC front panel to make sure that the volume level is below -25dB.

- The e28 DAC can be controlled from the front panel buttons, using an IR remote control or from the computer screen.
- Make sure that all cables are connected. Turn on the unit using the **Power** button on the front panel of the remote control. The front panel display will light up. After powering on the **USB Input** is selected by default.
- Click on the exaSound e28 Dashboard Icon in the System Tray area next to the clock.

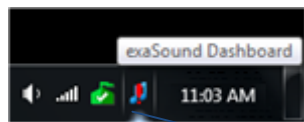

System Tray

exaSound Dashboard Icon

- You will see the exaSound e28 Dashboard window.

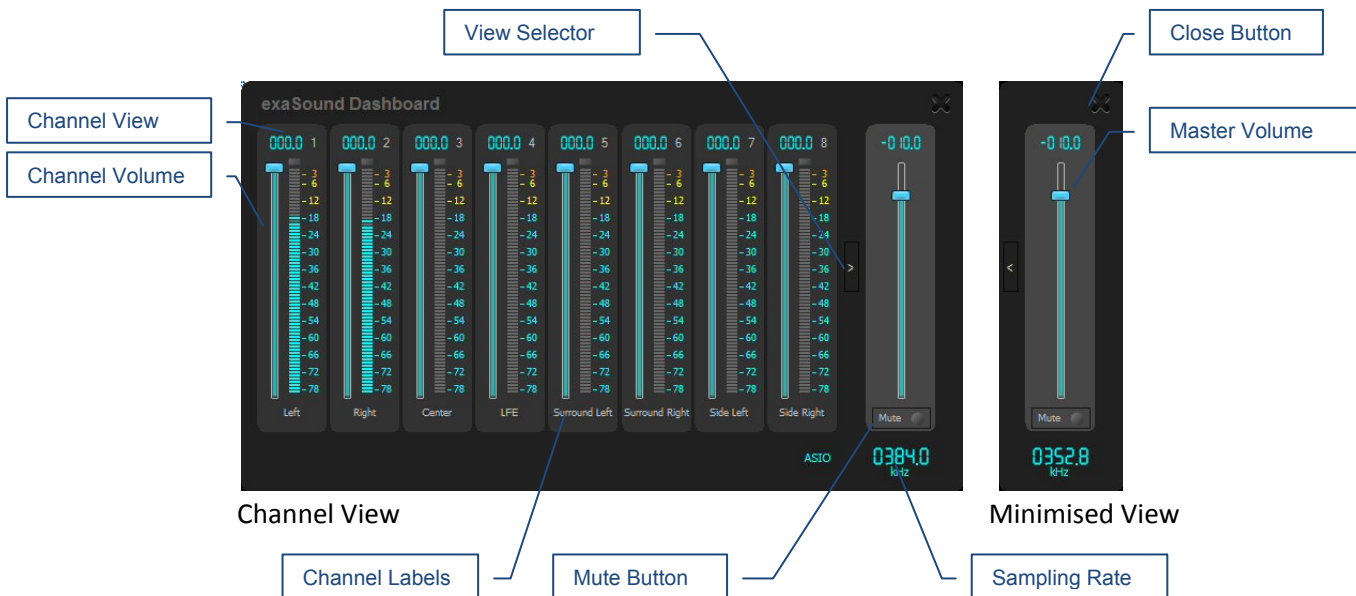

The screenshot shows the exaSound e28 Dashboard window in two states. On the left is the 'Channel View', which displays eight vertical volume sliders for different audio channels: Left, Right, Center, LFE, Surround Left, Surround Right, Side Left, and Side Right. Each slider has a scale from 000.0 to -78 dB. A 'View Selector' is located at the top of this view. On the right is the 'Minimised View', which shows a single 'Master Volume' slider and a 'Mute' button. A 'Close Button' is located at the top right of this view. At the bottom of the Channel View, there is a 'Mute Button' and a 'Sampling Rate' display showing '0384.0 KHz'. 'Channel Labels' are also indicated at the bottom of the Channel View.

- During playback the current sampling rate is displayed under the master volume slider.
- You can customize the channel labels: Select a label with the mouse and edit the channel title. Press **Enter** to save or **Cancel** to undo the change.

- Use the arrow button between the right channel and the master volume to toggle between **Channel View** and **Minimised View**.
- Use the **X** button in the top right corner to minimize the exaSound e28 Dashboard window.

Power On/Off

- The e28 DAC has an automatic power-on function and it will turn itself on when playback is detected.
- The e28 DAC automatically turns itself off after a period of inactivity. Use the *Power Off Timeout* setting to adjust the inactivity time interval before shutdown.

Volume Control

The e28 DAC volume is controlled by the ES9018 DAC chip. It is completely independent from the Windows software volume control and it preserves the maximum possible signal to noise ratio.

The volume level changes in steps of 0.5 dB. At first power on, the volume level is set to -40dB. When the dashboard is closed it remembers the volume level settings.

Use the sliders on the exaSound e28 Dashboard window to control the volume for individual channels, and the master volume. The sliders can be controlled in several ways:

- By left-clicking and dragging a slider
- By positioning the mouse cursor over a channel and turning the mouse wheel. When the mouse cursor is rested over the channel area the background color changes to indicate that the channel is active
- By selecting a channel with the mouse and using the **Up** and **Down** arrow keys on the keyboard

The master volume can also be controlled from the device front panel or using a remote control. When the master volume level is changed, the value displayed on the exaSound e28 Dashboard and on the device front panel display are synchronised.

Volume levels for individual channels can be controlled only from the exaSound e28 Dashboard.

The sound can be muted by clicking the **Mute** button under the master volume slider or by using the remote control. Pressing or clicking **Mute** again restores the previous volume level. Pressing **Volume Up** or **Volume Down** will cancel the mute state.

Make sure that your player application is configured to use the e28 DAC in ASIO mode (Configuration instructions Foobar2000 and JRiver are available on the exaSound Blog:

<http://www.exasound.com/Blog/tabid/74/articleType/CategoryView/categoryId/10/Guides.aspx>).

Start playback. You will see the level indicators moving and the current sampling rate displayed on the exaSound Dashboard. The e28 DAC front panel display will indicate the stream format (PCM or DSD), the sampling rate and the master volume level.

Note: level indicators are inactive in DSD mode.

Volume Bypass

When the volume sliders for the exaSound driver in the Audio MIDI Setup application are set to 0dB, the hardware volume control is turned off and the e28 DAC operates in Volume Bypass Mode.

To activate Volume Bypass:

- Set the master volume slider to 0dB.
- Set the left and right volume sliders to 0dB.
- Make sure that your player is not changing the volume level.

JRiver / JRemote Volume Synchronization Plug-in

The exaSound Volume Synchronization Plug-in allows JRiver 20 for Windows and JRemote to access the hardware volume control built in all exaSound DACs.

- Moving the JRemote or JRiver volume slider changes the master volume slider on the exaSound Dashboard.
- Changing the master volume with the exaSound Dashboard adjusts the JRemote / JRiver volume sliders.

Check the *Guides* section of the exaSound Blog for step-by-step configuration instructions for the exaSound Volume Synchronization Plug-in: exasound.com/Blog.aspx.

Settings Menu

- Click on the exaSound icon on the Menu and select Settings.
- Use the *Max Volume* setting to prevent accidental playback at volume levels that are too loud.
- The e28 DAC automatically turns itself off after a period of inactivity. Use the *Power Off Timeout* setting to adjust the time interval before shutdown.

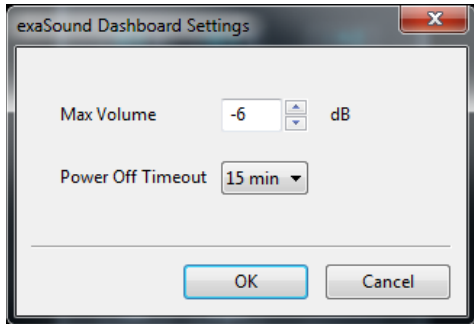

Settings changes may not come into effect until playback is restarted.

Step-By-Step Player Configuration Instructions

Check the *Guides* section of the exaSound Blog for player step-by-step configuration instructions: exasound.com/Blog.aspx.

Playing Music from SPDIF Sources

The e28 DAC makes it possible to enjoy greatly improved level of sonic clarity and fidelity from stereo SPDIF sources. The sonic improvement is the result of the outstanding jitter cancelling capability, superb signal to noise ratio, and low distortion levels of the e28 DAC.

You can connect up to two SPDIF devices, such as disk players and wireless music servers.

To use SPDIF sources:

1. Select SPDIF input by pressing the **Input** button on the device front panel or by using the **Previous Input / Next Input** buttons on the remote control.
2. The e28 front panel display will flash a **Changing Input** message.
3. The e28 front panel will display information about the input in use, the current sampling rate, and the master volume level.



Specifications

D/A Converter IC	ESS Technology ES9018S <i>Sabre32</i> Reference DAC
PCM Sampling Rates - Asynchronous USB ASIO	44.1kHz, 48 kHz, 88.2 kHz, 96 kHz, 176.4 kHz, 192 kHz, 352.8 kHz, 384 kHz
DSD Sampling Rates - Asynchronous USB ASIO	DSD 64 Fs: 2.8224 MHz, 3.072 MHz DSD 128 Fs 5.6448MHz, 6.144 MHz DSD 256 Fs: 11.2896 MHz, 12.288 MHz
Sampling Rates-SPDIF Coaxial IN 1	PCM 44.1kHz, 48 kHz, 88.2 kHz, 96 kHz, 176.4 kHz, 192 kHz
Sampling Rates-SDIF Optical IN 2	PCM 44.1kHz, 48 kHz, 88.2 kHz, 96 kHz
Total Harmonic Distortion + Noise	0.000359% @ 1KHz, 0dBFS
Intermodulation Distortion	-124 db / 0.0000605% % @ 19KHz + 20KHz 0 dBFS 2nd order IMD
Signal-to-Noise Ratio	125 dB, A-weighted, 2 Vrms
DAC Master Clock Jitter	e28: 0.13psec rms; e28 FC: 82fsec rms
Frequency Response	0 Hz - 20 KHz (-0.15dB)
Phase	Non-inverting
Channel Separation	134 dB @ 1KHz for adjacent channels 123 @ 1KHz between channel groups
Digital Inputs	USB 2.0, SPDIF Coaxial, SPDIF TOSLINK (optical)
Number of channels	2 to 8 channels PCM, DSD
Operating System Requirements	Windows 8 x86, Windows 8 x64, Windows Server 2012 R2, Windows 7 x86, Windows 7 x64, Windows XP x86 (ASIO Compatible Player is required for all Windows platforms) Mac OS X Mavericks, Mac OS X Yosemite
Digital Volume Control Steps	0.5 dB

Volume Matching between Channels	Better than 0.1 dB
Line Output	Unbalanced (RCA) or Balanced (Mini -XLR), gold-plated contacts
Line Output Level	4 Vrms (balanced) 2 Vrms (unbalanced)
Line Output Impedance	200 ohms
Line Output Offset	< 5 mV
Headphone Amp Current Output	200 mA peak
Headphone Amp Output Impedance	1 Ohm, 20Hz-20KHz
Headphone Amp Output	0-4V
Headphone Amp THD+N	0.00077% , 1Vrms into 60ohms
Headphone Jack	1/4" TRS SE
Power Jack Diameter	Internal: 2.5mm x External: 5.5mm
Power Consumption	<15 W
Dimensions (W x H x D)	6.5 x 2.2 x 9.25 inches (165 x 55 x 235 mm)
Weight	2.4 lbs (1.1Kg)

Limited One Year Warranty

exaSound Devices are warranted against defective workmanship or materials for one (1) calendar year from the original date of purchase. This warranty applies only to exaSound brand products manufactured by exaSound and sold to the original consumer by either exaSound or an exaSound authorized reseller. This warranty does not apply to exaSound brand products imported and sold by unauthorized dealers, distributors, or other sellers. exaSound may at its sole discretion, refuse to honour the warranty of any such unauthorized product that may be presented for service.

Warranty service can only be performed by exaSound. Devices which are defective must be shipped pre-paid and insured to exaSound for warranty service in accordance with our Return Policy published at <http://www.exasound.com/Store/TermsOfUse.aspx>. For products that we verify to be eligible for warranty service, we will pay the shipping cost to return the Device to you via ground shipment.

If in our assessment the defect is covered by our Warranty, the defective item will, at our sole option, be repaired, replaced with the same item or its functional equivalent, or the purchase price will be refunded. ExaSound in its sole and absolute discretion shall be the sole determiner of whether a product is in fact defective.

Replacement parts and products assume the remaining original warranty, or ninety (90) days, whichever is longer.

This limited warranty covers non-commercial use of this product, and shall not apply to the following, including, but not limited to: applications and uses for which this product was not intended; altered product or serial numbers; cosmetic damage or exterior finish; batteries and cable accessories; accidents, abuse, neglect, fire, water, lightning or other acts of nature; incorrect electrical line voltage, fluctuations and surges; failure to follow operating or maintenance instructions. ExaSound does not warrant uninterrupted or error-free operation of the product. This limited warranty shall not extend to anyone other than the original purchaser of the product. It is non-transferable and states your exclusive remedy.

ExaSound hereby expressly disclaims all liability for product defect or failure, that are due to normal wear, product misuse, physical tampering, abuse, product modification, improper product selection, non-compliance with any codes, misappropriation or the failure of the Device while being used for purposes for which it was not intended.

THE FOREGOING WARRANTY IS THE ONLY WARRANTY WITH RESPECT TO THE DEVICES AND WE MAKE NO OTHER WARRANTY WHATSOEVER, EXPRESS OR IMPLIED, REGARDING THE DEVICES INCLUDING MERCHANTABILITY AND FITNESS FOR A PARTICULAR PURPOSE. IN NO EVENT WILL EXASOUND, OR ITS AUTHORIZED RESELLERS BE LIABLE FOR INCIDENTAL, CONSEQUENTIAL OR SPECIAL DAMAGES, EVEN IF SUCH DAMAGES RESULT FROM NEGLIGENCE OR OTHER FAULT.

TO REGISTER YOUR PURCHASE FOR WARRANTY, please visit the following Web site:
<http://www.exasound.com/registration.aspx>

TO OBTAIN WARRANTY SERVICE, please follow these instructions:

- Contact exaSound customer service via email at CustomerService@exaSound.com with details of the defect claimed, product model, serial number, date and place of the original purchase.
- If it is determined that your product needs service, a Return Merchandise Authorization (RMA) number will be issued to you along with return instructions and address of an exaSound service center.
- Pack the product securely in the original packaging, with your assigned RMA number marked clearly on the outside of the package. Send the package pre-paid and insured to the exaSound to obtain warranty service.
- All returns must comply with our Return Policy displayed at <http://www.exasound.com/Store/TermsOfUse.aspx>.